

Dense Medium Controller Specification

(F01-200000-455 revision 1.3)

Important: Specifications are subject to change



A non-nuclear density meter for the measurement of slurries containing magnetic particles. Ideal for the density measurement of magnetite or ferro-silicon slurries as utilised in Dense Medium Separation plants.

Principle of operation: An electromagnetic field is created around the slurry which interacts with either magnetite or ferro-silicon. Both magnetite and ferro-silicon are magnetic. The higher the density of the slurry, the greater is the amount of magnetic particles and hence the greater the magnetic interaction. This magnetic interaction is precisely measured and converted to a density reading.

Application: Ideal for correct medium slurry density measurement in Dense Medium Separation (DMS) or Heavy Medium Separation (HMS) plants as typically found in the diamond, coal, andalusite, chrome and iron ore mining industries.

NO RADIOACTIVE SOURCE



The Dense Medium Controller (DMC) is designed to measure the density of slurries accurately and reliably in Dense Medium Separation plants. The technology used is non-nuclear and has been used in the diamond industry for over a decade. Being non-nuclear eliminates the legislative, safety, environmental and personnel skill requirements associated with nuclear densitometers.

Characteristics

- Non-nuclear density measurement device.
- Suitable for Magnetite, Milled FeSi and Atomised FeSi slurry applications.
- Density measurement independent of flow rate.
- Non-contact.
- No moving parts.
- Non-obtrusive to flow – no pressure drop.
- Standard analog and various fieldbus output options.
- No maintenance – no periodic internal cleaning required.
- In-field, one point Quick Calibration - no process adjustment or shutdown required.
- On-Off control output for dosing of dilution water.
- PID analog control output (4-20mA) for more controlled dosing of dilution water.
- Density out-of-range output for an alarm beacon indicator.
- Various fieldbus options available.

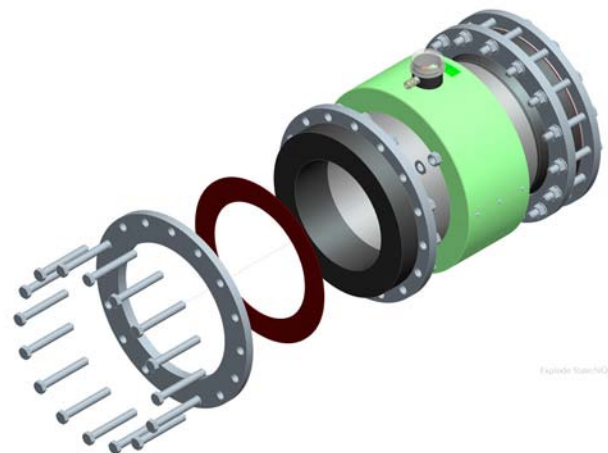

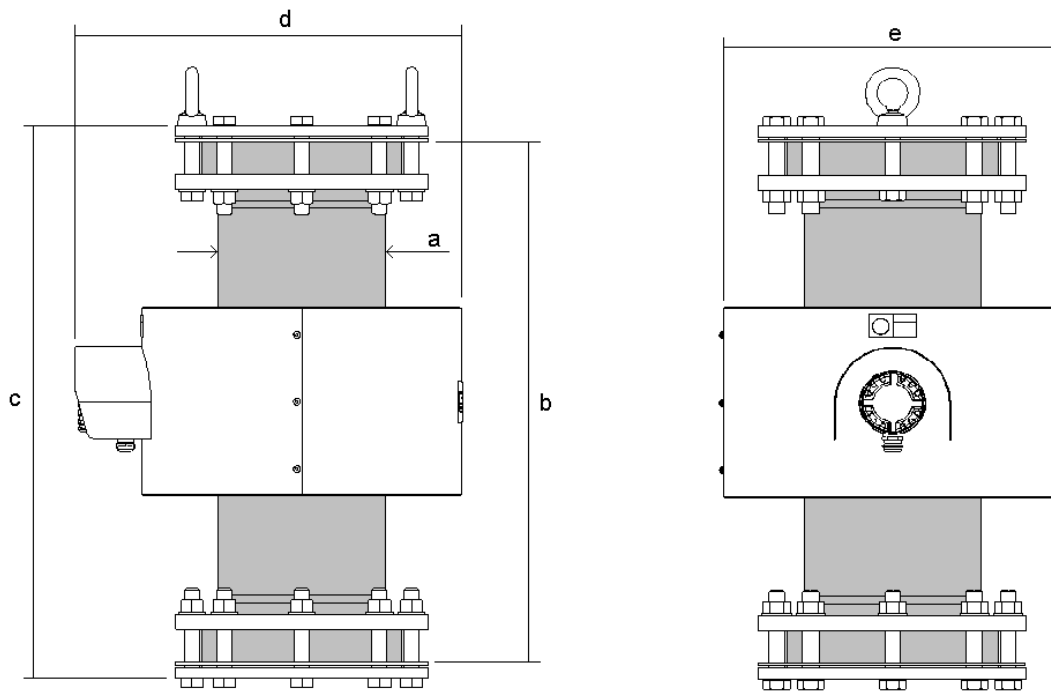

Transducer dimensions

DMC Transducer unit	a	b	c	d	e	External flange specification	Bolt specification
	pipe outer diameter	stub flange to stub flange distance	facing flange to facing flange distance	maximum cover width	minimum cover width		
	mm [inch]	mm [inch]	mm [inch]	mm [inch]	mm [inch]		
DMCT050	50 [1.97]	450 [17.72]	476 [18.75]	254 [10]	165 [6.50]	40NB SABS 1123 NP/3	M16 x 70 mm galvanised
DMCT075	75 [2.96]	450 [17.72]	480 [18.90]	294 [11.58]	203 [8.0]	65NB SABS 1123 NP/3	M16 x 70 mm galvanised
DMCT110	110 [4.33]	550 [21.66]	580 [22.84]	362 [14.26]	275 [10.83]	100NB SABS 1123 NP/3	M16 x 80 mm galvanised
DMCT160	160 [6.30]	550 [21.66]	588 [23.15]	396 [15.60]	303 [11.93]	150NB SABS 1123 NP/3	M20 x 100 mm galvanised
DMCT225	225 [8.86]	700 [27.56]	742 [29.22]	519 [20.44]	430 [16.93]	200NB SABS 1123 NP/3	M20 x 120mm galvanised
DMCT315	315 [12.41]	750 [29.53]	800 [31.50]	631 [24.85]	542 [21.34]	300NB SABS 1123 NP/3	M20 x 150mm galvanised
DMCT355	355 [13.98]	750 [29.53]	806 [31.74]	671 [26.42]	581 [22.88]	350NB SABS 1123 NP/3	M20 x 140mm galvanised

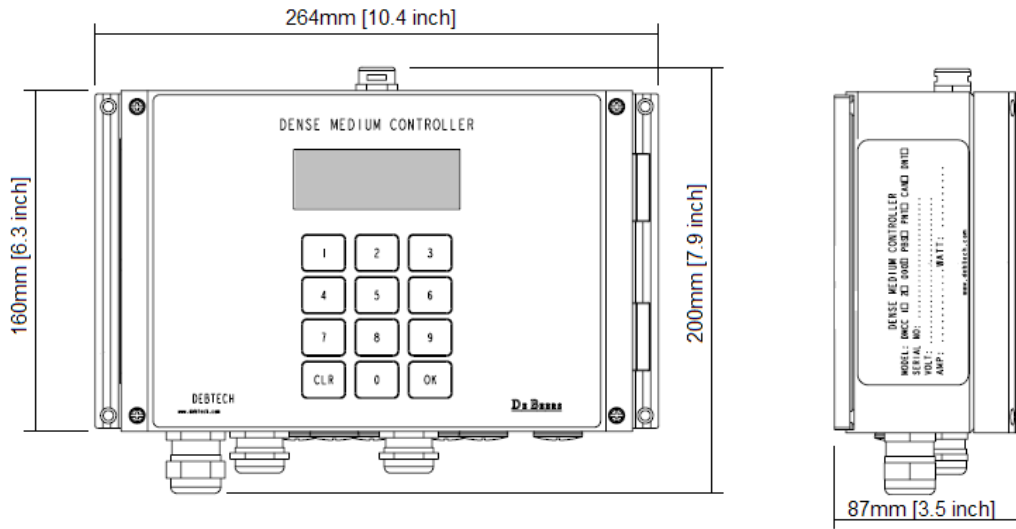

Dense Medium Controller	DMCT50	DMCT 75	DMCT 110	DMC T160	DMC T225	DMC T315	DMC T355
Process pipe outer diameter [mm]	50	75	110	160	225	315	355
Process pipe outer diameter [inch] (approximate)	2	3	4	6.3	8.9	12.4	14
Process pipe inner diameter [mm] (approximate)	40	61	89	130	183	256	288
Process pipe inner diameter [inch] (approximate)	1.6	2.4	3.5	5.1	7.2	10.1	11.4
Measurement range:							
Magnetite slurry [S.G.]	1.00 to 2.20						
Milled Ferrosilicon (FeSi) slurry [S.G.]	1.00 to 3.80						
Atomised FeSi slurry [S.G.]	1.00 to 4.50						
Accuracy: ^{1,2}							
Magnetite slurry [S.G.]	± 0.01	±0.01	±0.01	±0.01	±0.02	±0.02	±0.02
Milled FeSi slurry [S.G.]							
Atomised FeSi slurry [S.G.]							
Temperature coefficient ³ [S.G./°C]	0.0001	0.0001	0.0001	0.001	0.002	0.002	0.002
Measurement rate	Continuous						
Update interval [sec]	5						
Transducer mass [kg]	12	17	26	38	66	110	146
Transducer mass [lb] (approximate)	27	38	58	84	146	243	322
Ambient Temperature [°C]	-10..60 [14..140 °F]						

NOTE: 1. Accuracy specified using pure FeSi/ Magnetite and water slurries.

2. Accuracy specified for a maximum coil temperature variation of 10°C. Actual coil temperature can be read off the DMC Controller. To achieve best accuracy, minimise the temperature swing of the DMC Transducer.
3. Variation in measured density due to 1 degree change in coil temperature. Actual coil temperature can be read off the DMC Controller.

DMC Transducer details

Material:

Pipe/ spool:	High Density Polyethylene (HDPE) PN16 PE100 SDR 11
Backing flanges:	SABS 1123, used with HDPE stubs. Hot dipped galvanised to SABS 763.
Stub flange:	Class 10 HDPE/PP
Flat face flanges:	SABS 1123 Type NP/3, 1000/3, NP 1000kPa, Steel flanges, not galvanised, for welding onto existing steel pipework, where applicable.
Metal body:	3CR12 utility stainless steel, 304/ 316 stainless steel in part. Powder coated, blue, hammer finish.

Installation:

- At least 0.3m away from an upstream or downstream bend in the pipework.
- The transducer should be installed vertically. Note: This instrument will function when mounted horizontally, however a full volume of slurry must be guaranteed to obtain true density readings. The medium must not be allowed to settle inside the instrument when mounted horizontally. Any settling of medium inside the Transducer will affect the density measurement.
- The cable gland must face downwards. Rotate the Transducer electronics housing away from direct sunlight.
- To minimise the undesired effect of the temperature coefficient, do not install the Transducer in direct sunlight.

Degree of protection:

IP66, certified by the SABS to SANS 60529:2001

DMC Controller details

Controller material:

Enclosure: Powder coated aluminium DIN EN 1706 EN AC-AISI 12 (Fe). Colour: RAL 7038, agate grey.

Controller power supply:

Recommended: 85 to 264 VAC (47 to 63 Hz), 0.4A RMS at 230 VAC/ 120 to 370 VDC

Alternate: Bypassing the internal power supply unit: 24VDC 1.1A

The Controller PCB is protected against reverse polarity.

General:

- Tactile touchpad for local configuration
- LCD screen with 4x20 characters, permanently backlit

Total mass of Controller:

- 2,5 kg [5.6lb]

Analog output (standard):

- 4 to 20mA, 0 to 20mA, 0 to 24mA or 0-10VDC
- 16 bit resolution
- Galvanic isolation

Serial interface (standard):

- RS-232, meets EIA-232-E and V.28 specifications
- Settings:
 - baud rate 9600, 8 data bits, No parity, 1 Stop bit, hardware flow control

Fieldbus output (Optional):

- Currently available: Profibus DP, Ethernet/IP, Modbus/TCP
- On request: Profinet, CANopen, DeviceNet

Transducer to Controller cable:

- 6 core, 0.5mm² screened multi-core cable
- 25m cable length supplied, pre-wired at Transducer end
- CSA compliant version supplied on request

Installation:

- It is recommended that the Controller be installed within an enclosure to protect it from the environment. A see-through front panel will aid in reading the density without having to open the enclosure.
- Install the Transducer away from direct sunlight and away from splashing slurries.
- The Controller can be mounted in the plant environment at an ergonomic location at a recommended maximum (cable length) distance of 25m (supplied) from the Transducer. Since the cable length is constrained by the RS232 communication between the Controller and Transducer, longer cable lengths may be possible but must first be tested. After routing, the cable must be reduced to its minimum length before connection to the Controller.

Degree of protection:

IP65, certified by the SABS to SANS 60529:2001

Calibration frequency: The unit must be calibrated at least once a week or as determined by site experience. This requires a Quick Calibration which takes approximately one minute to perform without the need to change the slurry density.

System connection layout

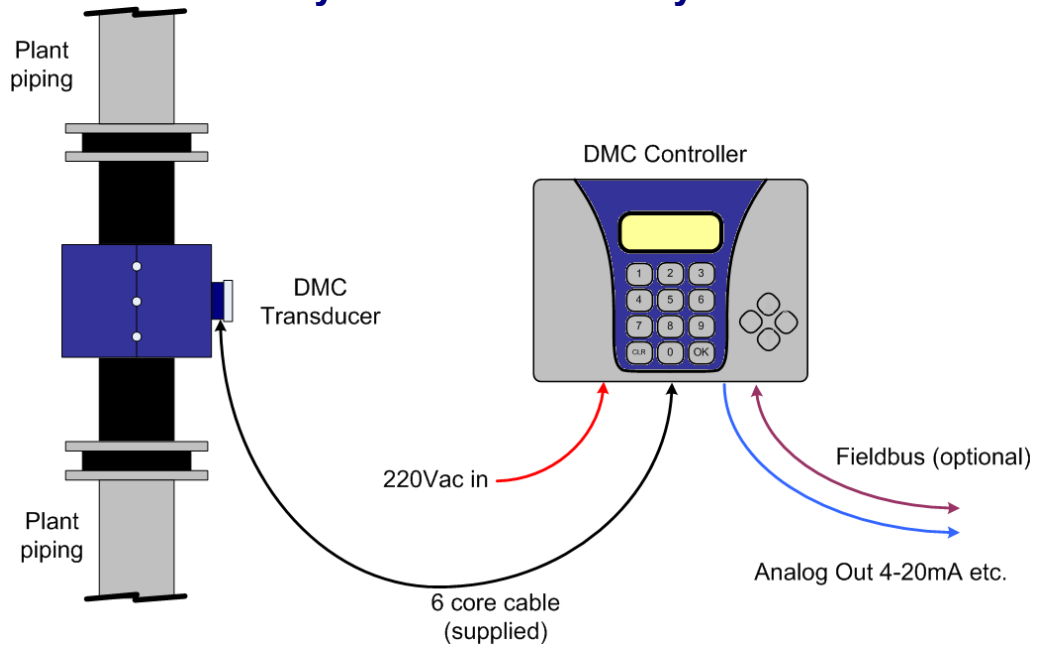

All copyrights and trademarks are the property of their respective holders.

www.debtech.com

DebTech – De Beers, 59 Crownwood Road, Theta, Johannesburg, South Africa, 2013
Tel: +27 11 374 7333, Fax: +27 11 374 5333
email: debtech@debeersgroup.com